

The Delta SM series solar modules are manufactured from high efficiency solar cells of Grade A quality class, which guarantees high performance, durability and reliability. The strength of the modules is provided by the use of a tempered glass and an anodized aluminum profile frame (with drainage holes). Exclusive module's frame prevents its deformation under extreme weather conditions.

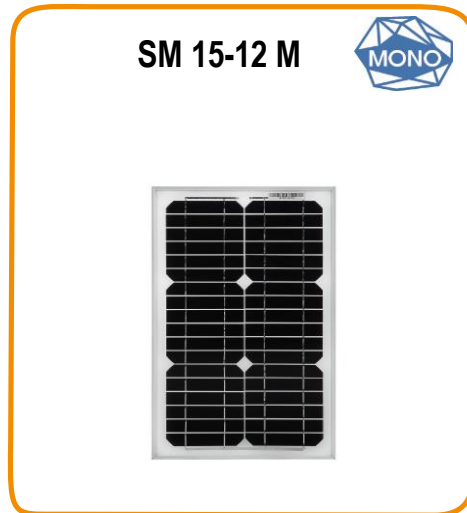

Cells

Technology.....	Mono crystal
Cell thickness	180 µm
Number of cells.....	36 (2x18)
Quality class	Grade A

Electrical parameters (STC)*

Peak electrical power (P _{max}).....	15 W
Tolerance.....	+3 %
Nominal voltage (U _{nom}).....	12 V
Voltage at maximum power point (U _{mp}).....	18,21 V
Current at maximum power point (I _{mp}).....	0,83 A
Short-circuit current (I _{sc}).....	0,88 A
Open-circuit voltage (U _{oc}).....	21,86 V
Maximum series fuse rating.....	15 A
Cell efficiency	16,81 %
Module efficiency	10,83 %

*Standard measurement conditions (STC): light density 1000 W/m², air mass AM = 1.5,

nominal temperature 25°C

Temperature coefficients

NOCT* (±2°C).....	45±2°C
Of power (P _{max}).....	-0,44 %/°C
Of voltage (U _{oc}).....	-0,34 %/°C
Of current (I _{sc}).....	0,06 %/°C
Operating and storage temperature	-40 ÷ 85°C

*NOCT - normal operating temperature of solar module

Mechanical characteristics

Module dimensions.....	390 x 355 x 18 mm
Weight.....	1,9 kg
Front glass.....	Tempered non-reflecting glass 3.2 mm
Frame.....	Anodized aluminum
Terminal box	IP 65
Connectors.....	MC4
Cable length	300 mm
Output cable	0,5 mm ²
Number of diodes.....	1
Wind load.....	5400 Pa

Quality and warranty

- The quality control complies with IEC61215 and IEC61730 standards.
- The warranty for solar module is 10 years and does not cover any damages caused by mechanical, thermal or other external actions.
- The manufacturer guarantees that more than 90% of the declared nominal power will be retained for 10 years. 80% of the declared minimum nominal power will be retained for 25 years.

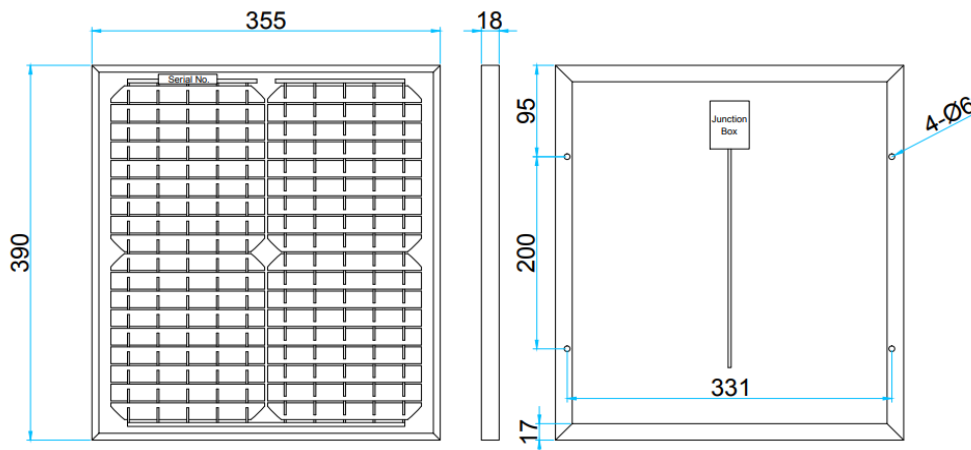

ATTENTION! The solar module should be installed and connected by a qualified technician with the corresponding access level. While connecting the solar module, strictly observe the connection polarity. Be sure to use a solar charge controller to charge the battery and power the load. Before using the module, read the manual carefully.

Our products are constantly being improved, so we reserve the right to make changes without prior notice.